

CEILING SYSTEMS  
MODULAR

# 220 series

LAY-IN/LAY-ON

Lay-In type T-Grid ceiling designed for internal application. Modular ceiling laid-in/on to a T-Grid (15mm/24mm) with exposed suspension system & revealed / non revealed / flush panel edges. Lift upwards out from grid to gain ceiling void access. Offered in a wide range of sizes, colors & finishes.

## FEATURES

### MATERIAL

Aluminum Alloy as per EN AW 3000 or 5000 series.

Zinc Plated Galvanized Steel G90 grade.

### THICKNESS

Aluminum: 0.5mm to 1.0mm

Galvanized Steel: 0.5mm to 0.8mm

+ Custom thickness are available upon request

### SURFACE FINISH

Plain  
Perforated  
Decorative Patterns

### COATING

Polyester Coating: ((5 $\mu$  (Back) + 20 $\mu$  (Face))

Polyester Powder Coating: (70 $\mu$  -80 $\mu$ )

+ High Performance Coatings like PESDF, PVDF and POLYAMIDE are available upon request.

### INSULATION

**Acoustic Black Fleece** is non-flammable and meets the standard DIN 4102 / B1. Classification A1 according to EN 13501-1.

**Rockwool** slabs conforming to ASTM C612 and equivalent BS 3958-5 are provided for acoustic insulation.

### COLORS

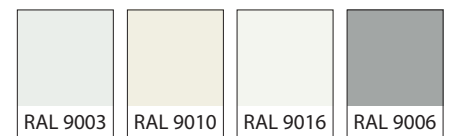

### SPECIAL FINISHES



+ See [www.rammatal.com](http://www.rammatal.com) for additional colors & special finishes available

+ Special finishes can be provided in lamination, sublimation or coil coating process.

### SIZES (mm)

Panel width	NORTILE LT / RAM 221	RAM 222	RAM 223
300 X 600	•		•
300 X 1200	•		•
600 X 600	•	•	•
600 X 1200	•		•
600 X 1800	•		•
1200 X 1200	•		•

+ Custom Sizes available upon request

### PERFORATION PATTERNS

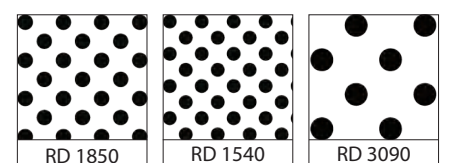

+ See [www.rammatal.com](http://www.rammatal.com) for all available pattern options

**DATA / PERFORMANCE**



**ACOUSTICS**  
 Tested as per BS EN ISO 354: 2003 for sound absorption, noise reduction and sound attenuation.  
 NRC achieved with Acoustic Black fleece – NRC 0.75  
 NRC achieved with Acoustic Black Fleece and Rockwool Insulation – NRC 1.00  
 Tested as per ASTM E1414-11a for Airborne Sound Attenuation as per ISO 10848-2.  
 CAC can achieved up to – 48 dB  
 Perforated & Sound Attenuation cover



**ANTI BACTERIAL COATING**  
 Tested as per JIS Z 2801: 2000, which inhibits the growth of bacteria on the applied surface.



**LIGHT REFLECTANCE (LR)**  
 Achieved by the metal ceiling is LR – 0.85-0.96 tested as per ASTM E 1477.



**FIRE PERFORMANCE**  
 Surface Spread of flame Class 1 tested as per BS 476: Part 7: 1997  
 “Non-Combustible” Material tested as per BS 476: Part4: 1970  
 Flame Spread and Smoke Development Index tested as per ASTM E84 (Class 1 or A)

**NORTILE LT / RAM 221 LAY-IN  
 RAM 222 GT15  
 RAM 223 LAY-ON**

**ISOMETRIC DETAIL**

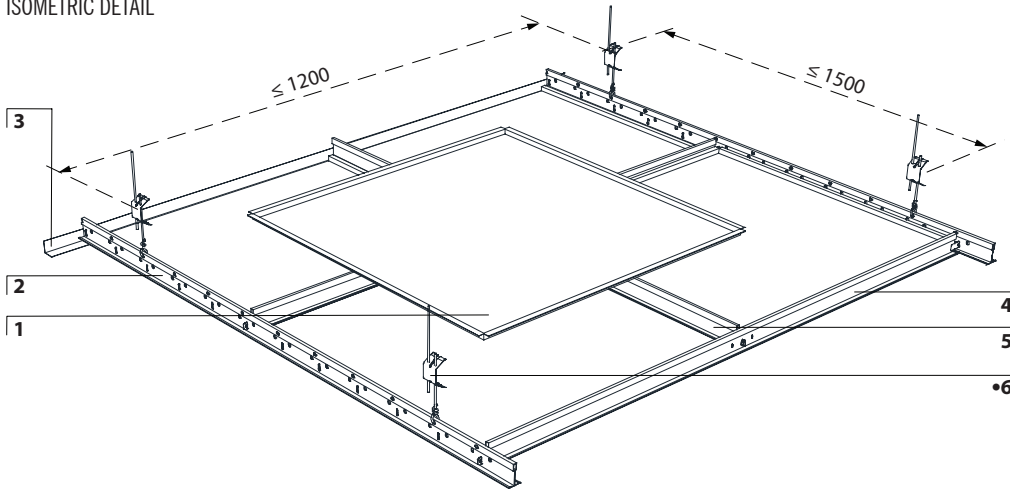

**COMPONENTS**

- 1 Panel
- 2 Main Carrier
- 3 Wall Trim
- 4 Primary Cross Tee 1200
- 5 Secondary Cross Tee 600
- 6 Adjustment Clip •
- 7 DS Bracket •
- 8 Threaded Rod •
- 9 Anti-Vibration Clip (TR) •
- 10 Wedge •



• Optional  
 Custom sizes can be offered

**PANEL-CARRIER JOINT DETAILS**

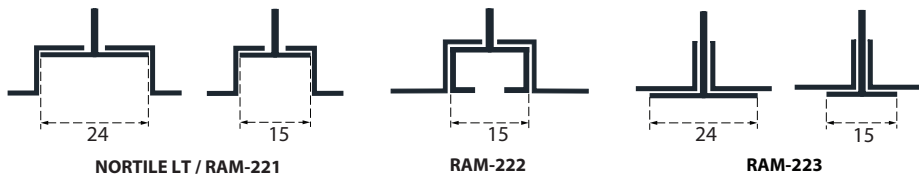

**OPTIONAL HANGING SOLUTIONS**

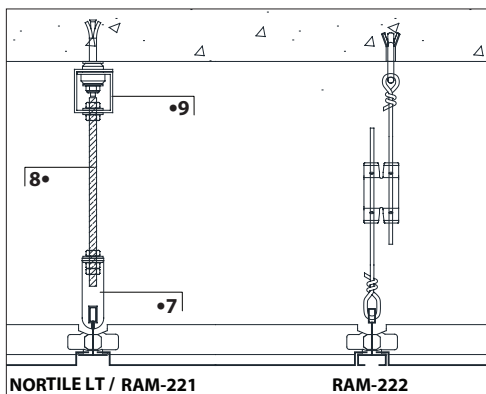

**PERIMETER OPTIONS**

