

CEILING SYSTEMS
TORSION SPRING

620 series

T

This hinge down type triangular torsion spring ceiling system with reveled edge is an ideal solution for mega size panels and multiple height ceilings. A highly sustainable and durable system. Available with sound attenuation panels. Can be manufactured in double skin. A heavy duty torsion spring system is with a secured panel to hinged down from the ceiling. Fully demountable with downward hinge down accessibility without using any special tool. Offered in a wide range of sizes, colors & finishes.

FEATURES

MATERIAL

Aluminum Alloy as per EN AW 3000 or 5000 series.

Zinc Plated Galvanized Steel G90 grade.

THICKNESS

Aluminum or Galvanized Steel:
0.5mm to 1.0mm.

- + Custom thickness are available upon request
- + Spring Material- Stainless Steel for both options

SURFACE FINISH

Plain
Perforated
Decorative Patterns

SIZE

TRIANGLE TYPE

Equilateral
Isosceles
Scalene

PANEL JOINT DETAIL

5-20 mm gap

- + Custom sizes are available upon request

COATING

Polyester Coating: ((5 μ (Back) + 20 μ (Face))

Polyester Powder Coating: (70 μ -80 μ)

- + High Performance Coatings like PESDF, PVDF and POLYAMIDE are available upon request.

INSULATION

Acoustic Black Fleece is non-flammable and meets the standard DIN 4102 / B1. Classification A1 according to EN 13501-1.

Rockwool slabs conforming to ASTM C612 and equivalent BS 3958-5 are provided for acoustic insulation.

COLORS

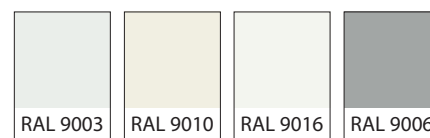

SPECIAL FINISHES



- + See www.rammetal.com for additional colors & special finishes available
- + Special finishes can be provided in lamination, sublimation or coil coating process.

PERFORATION PATTERNS

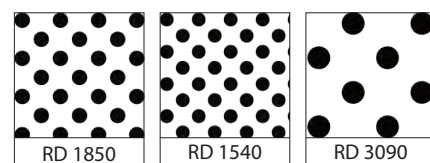

- + See www.rammetal.com for all available pattern options

DATA / PERFORMANCE



ACOUSTICS

Tested as per BS EN ISO 354: 2003 for sound absorption, noise reduction and sound attenuation.

NRC achieved with Acoustic Black fleece – NRC 0.75

NRC achieved with Acoustic Black Fleece and Rockwool Insulation – NRC 1.00

Tested as per ASTM E1414-11a for Airborne Sound Attenuation as per ISO 10848-2.

CAC can achieved up to – 48 dB

Perforated & Sound Attenuation cover



ANTI BACTERIAL COATING

Tested as per JIS Z 2801: 2000, which inhibits the growth of bacteria on the applied surface.



LIGHT REFLECTANCE (LR)

Achieved by the metal ceiling is LR – 0.85-0.96 tested as per ASTM E 1477.



FIRE PERFORMANCE

Surface Spread of flame Class 1 tested as per BS 476: Part 7: 1997

“Non-Combustible” Material tested as per BS 476: Part4: 1970

Flame Spread and Smoke Development Index tested as per ASTM E84 (Class 1 or A)

RAM 621 TRIANGULAR FLAT RAM 622 TRIANGULAR 3D

ISOMETRIC DETAIL

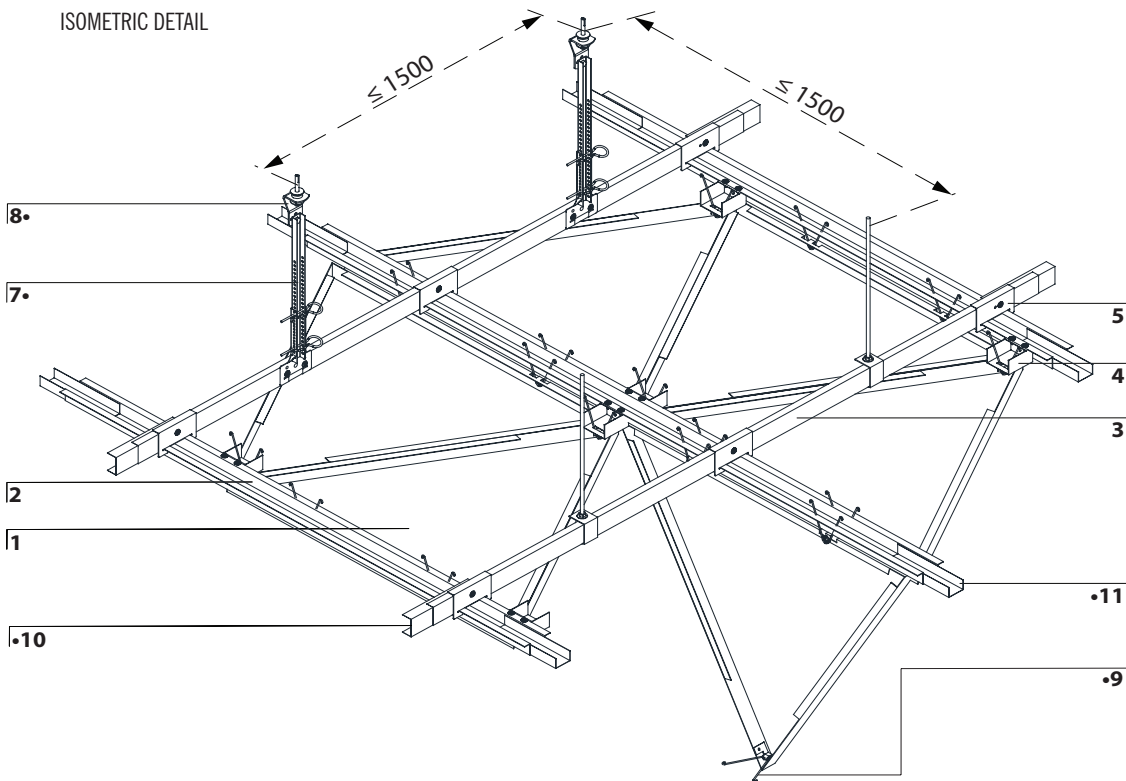

COMPONENTS

- 1 Panel (RAM 621)
- 2 Torsion Spring Carrier
- 3 Stabilizer
- 4 Carrier Projector
- 5 TC Bracket
- 6 Wall Trim
- 7 Rigid Hanging System •
- 8 Anti-Vibration Clip (RH) •
- 9 Torsion Spring Wire
- 10 ST Splice •
- 11 C Splice •
- 12 Universal Bracket •
- 13 Threaded Rod •
- 14 Anti-Vibration Clip (TR) •
- 15 Self-Adhesive Seal •
- 16 Spacer •



Luminous Panel •

SECTION DETAIL

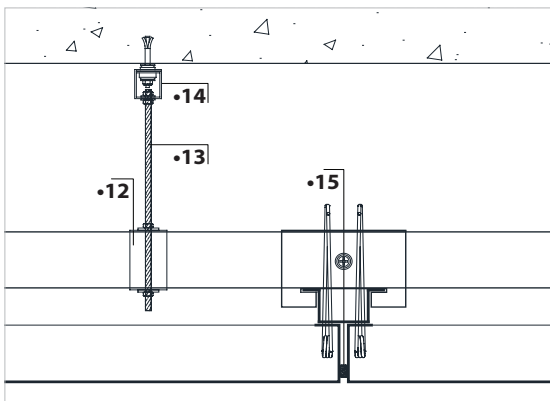

JOINT DETAIL



PANEL DESIGN PATTERN

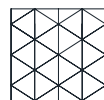

RAM-621

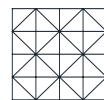

RAM-622

PERIMETER OPTIONS

