



CEILING SYSTEMS
SECURITY

810 series HIGH GUARD

A high guard ceiling type. Grade 1 is designed for maximum security and is ideal for prisons, detention centers, and other high security zones. Security access panel with master key solution available. Grade 4 is designed for light security and is ideal for airport washrooms, classrooms, light detention centers, and other light security zones. Security access panel with special tool available. Tested as per ASTM F2322-2012 standards for maximum Grade 1 criteria & tested for load bearing capacity. Offered in a wide range of sizes, colors & finishes.

FEATURES

MATERIAL

Zinc Plated Galvanized Steel G90 grade.

THICKNESS

Galvanized steel:
RAM 811: 2.0mm
RAM 812: 1.0mm

+ Custom thickness are available upon request

SURFACE FINISH

Plain
Perforated

SIZE

PANELS (mm)
600x600/600x1200

+RAM 811 (with security brackets)
+RAM 812 (with security lock)

+ Custom sizes are available upon request

COATING

Polyester Coating: ((5 μ (Back) + 20 μ (Face))

Polyester Powder Coating: (70 μ -80 μ)

+ High Performance Coatings like PESDF, PVDF and POLYAMIDE are available upon request.

INSULATION

Acoustic Black Fleece is non-flammable and meets the standard DIN 4102 / B1. Classification A1 according to EN 13501-1.

Rockwool slabs conforming to ASTM C612 and equivalent BS 3958-5 are provided for acoustic insulation.

COLORS

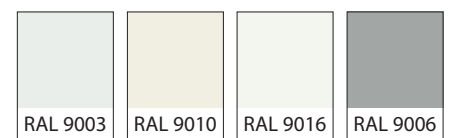

SPECIAL FINISHES



+ See www.rammatal.com for additional colors & special finishes available

+ Special finishes can be provided in lamination, sublimation or coil coating process.

PERFORATION PATTERNS

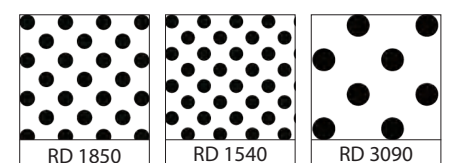

+ See www.rammatal.com for all available pattern options

DATA / PERFORMANCE



ACOUSTICS

Tested as per BS EN ISO 354: 2003 for sound absorption, noise reduction and sound attenuation.

NRC achieved with Acoustic Black fleece – NRC 0.75

NRC achieved with Acoustic Black Fleece and Rockwool Insulation – NRC 1.00

Tested as per ASTM E1414-11a for Airborne Sound Attenuation as per ISO 10848-2.

CAC can achieved up to – 48 dB

Perforated & Sound Attenuation cover



ANTI BACTERIAL COATING

Tested as per JIS Z 2801: 2000, which inhibits the growth of bacteria on the applied surface.



LIGHT REFLECTANCE (LR)

Achieved by the metal ceiling is LR – 0.85-0.96 tested as per ASTM E 1477.



SECURITY

Complies with ASTM F2322 standards for physical assault on vertical fixed barriers for detention and correctional facilities



FIRE PERFORMANCE

Surface Spread of flame Class 1 tested as per BS 476: Part 7: 1997

“Non-Combustible” Material tested as per BS 476: Part4: 1970

Flame Spread and Smoke Development Index tested as per ASTM E84 (Class 1 or A)

RAM 811 SECURITY CEILING GRADE 1 RAM 812 SECURITY CEILING GRADE 4

ISOMETRIC DETAIL

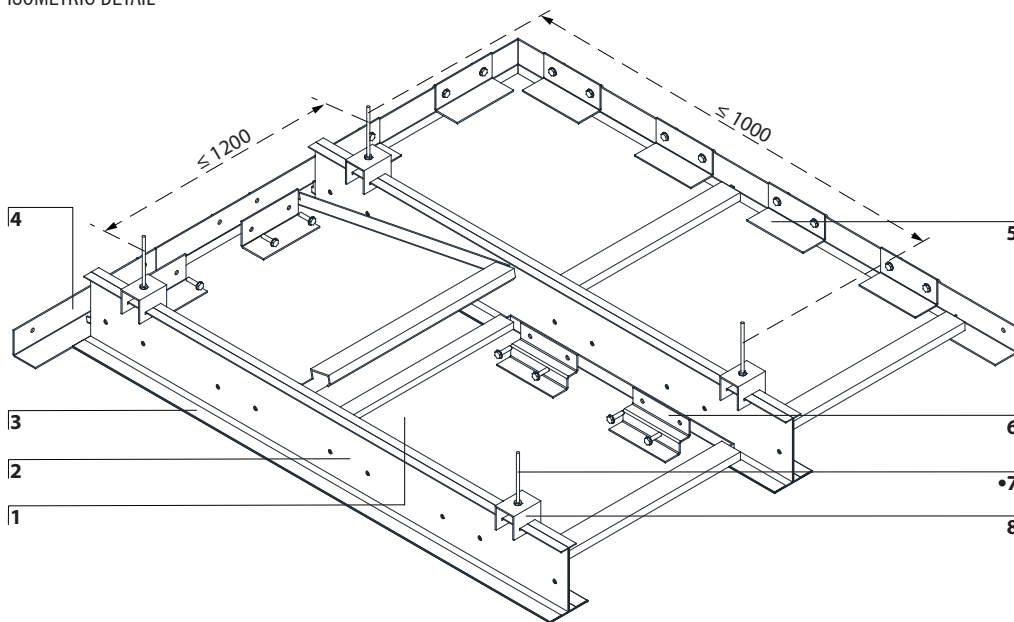

COMPONENTS

- 1 Panel
- 2 Carrier Profile
- 3 Carrier Cap
- 4 Wall Trim
- 5 L Wedge
- 6 W Wedge
- 7 Threaded Rod •
- 8 C Bracket
- 9 Narrow Carrier
- 10 Stabilizer
- 11 Security Plate
- 12 Budget Security Lock & Key
- 13 SL Bracket
- 14 NC Bracket
- 15 F Profile
- 16 Rigid Hanging System
- 17 Anti-Vibration Clip (RH) •

• Optional

Custom sizes can be offered

CROSS SECTION

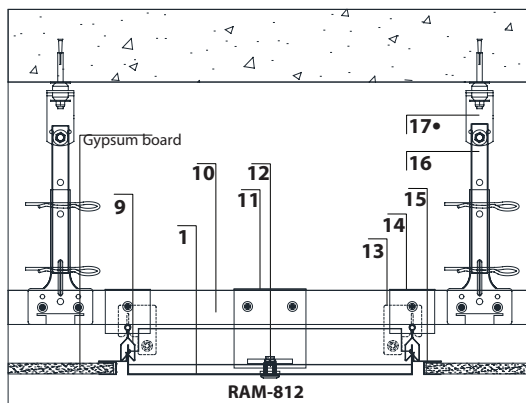

ACCESS PANEL SECTION

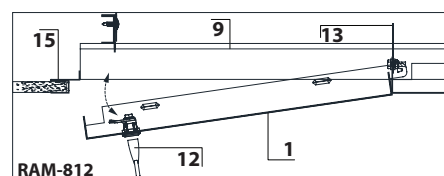

PERIMETER OPTION

